

2509.170

DATE	REVISION DESCRIPTION	AUTH

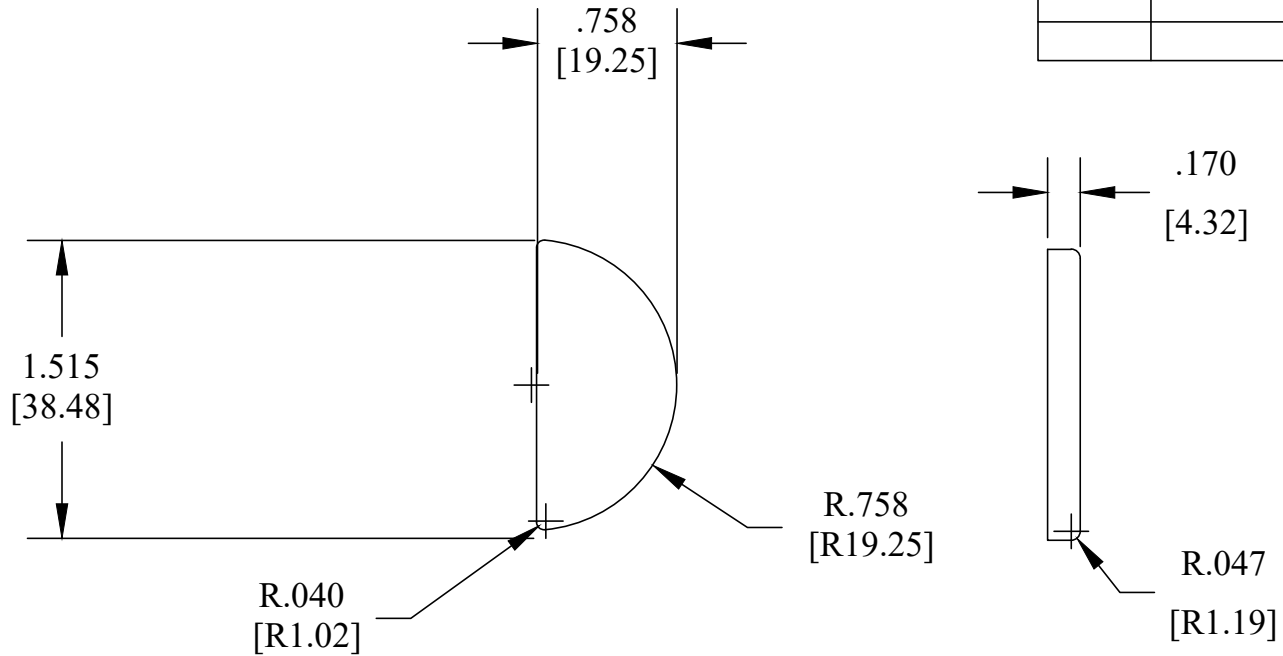

[] = MM

TOLERANCES	COSMETIC PAN		
INCH: ±.005 [±.13]	FELDWARE INC		
Radius: ±.010 [±.25]	DRAWN BY: D. Feldman	CODE: XXXXXXXXXXXXXX	
	DATE: JUNE 30, 2021		
	MATERIAL: 28 GAUGE TINPLATE	SCALE: 1:1	TOOL NUMBER: 2509.170

THIS DOCUMENT CONTAINS CONFIDENTIAL AND PROPRIETARY INFORMATION THAT CANNOT BE REPRODUCED OR DIVULGED, IN WHOLE OR IN PART, WITHOUT WRITTEN AUTHORIZATION FROM FELDWARE INC